

Electric Ship Power and Energy System Architectures

Dr. Norbert Doerry

Dr. John Amy Jr.

IEEE ESTS 2017

August

(Revision of April 7, 2026)

Liquefied Natural Gas (LNG) Carrier

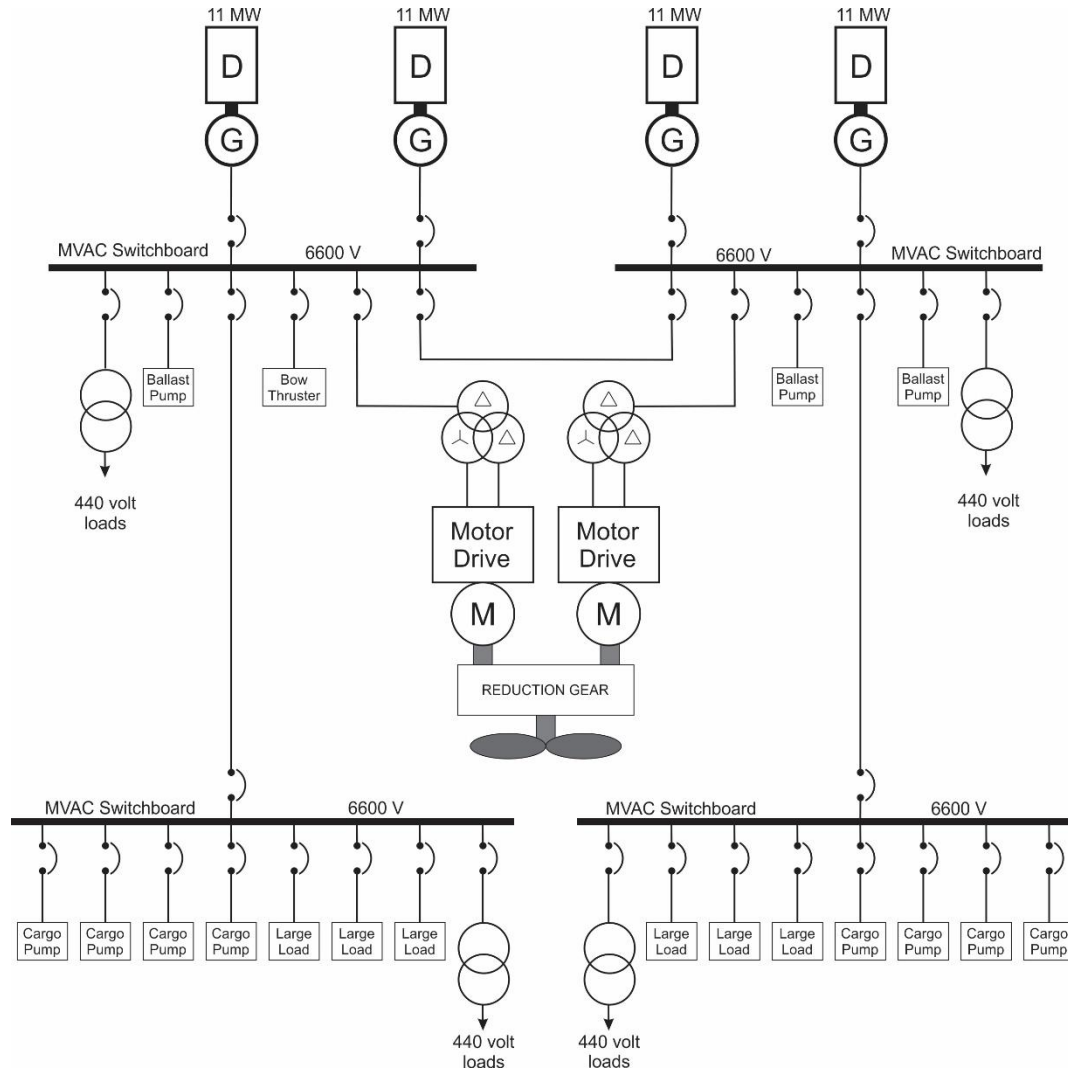

Cruise Ship



Regal Princess (Photo by Norbert Doerry)
 (<https://creativecommons.org/licenses/by/4.0/>)

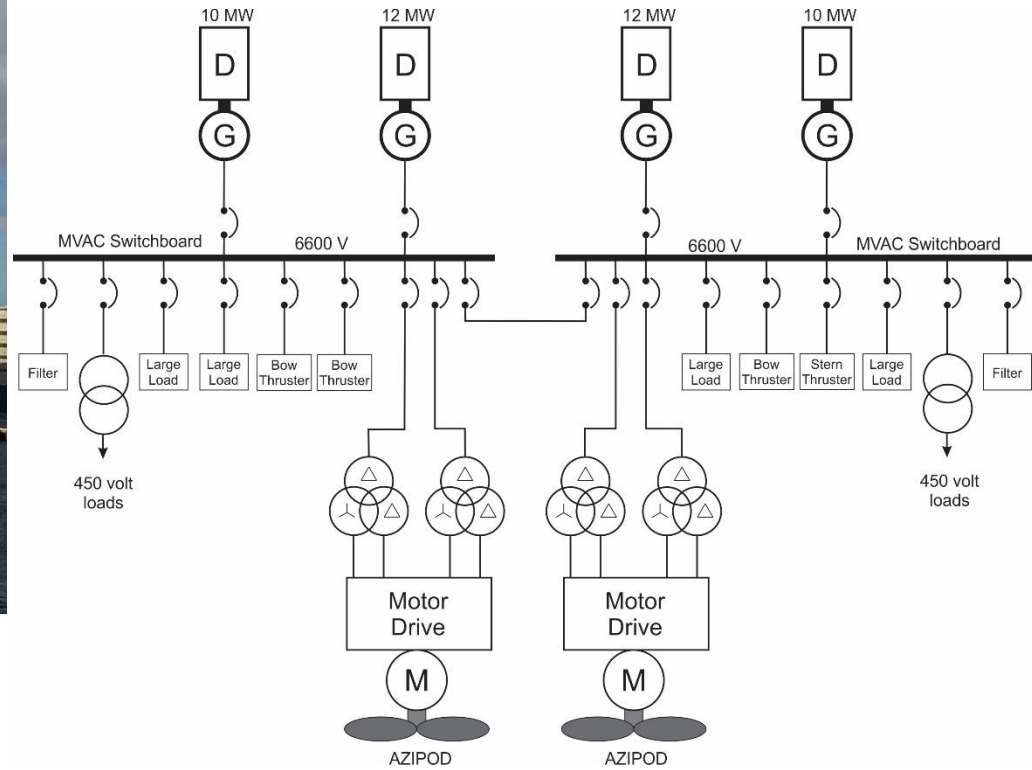

Platform Supply Vessel



Siem Symphony
 (photo by DXR: <https://creativecommons.org/licenses/by-sa/4.0/>)

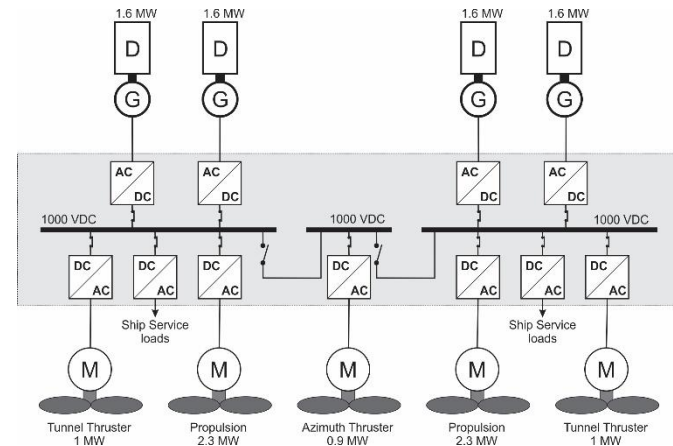
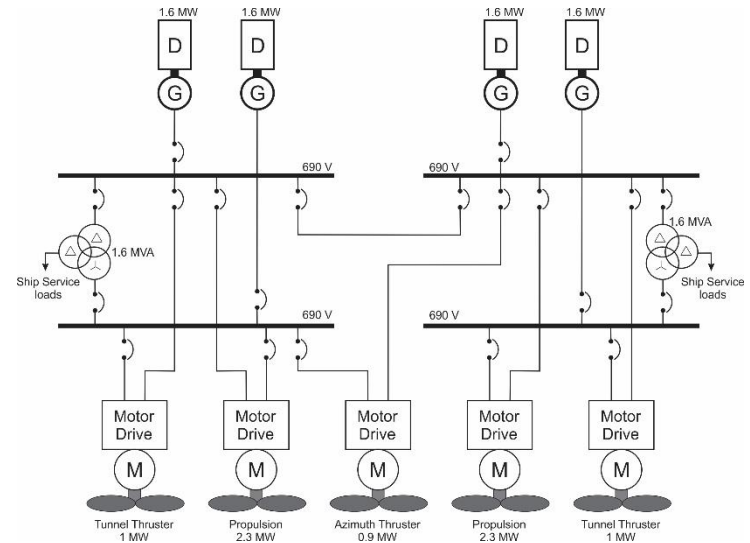

T-AGOR 23

Thomas G. Thompson



photo by Bahnfreund: <https://creativecommons.org/licenses/by-sa/4.0/>

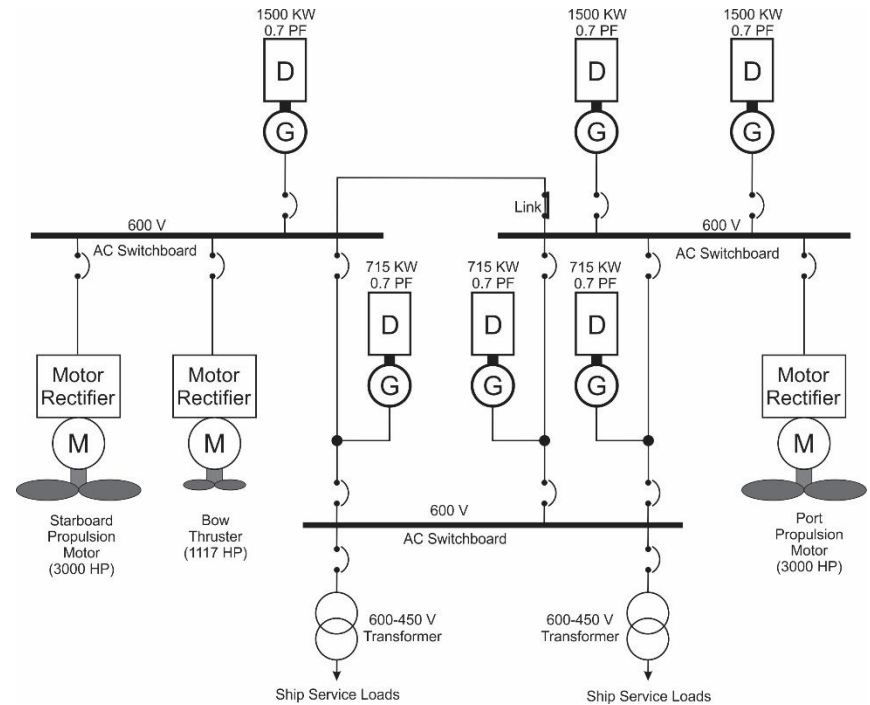

WLBB 30

USCGC Mackinaw



USCGC Mackinaw (WLBB 30)
(US Coast Guard Photo by PA3 George Degener)

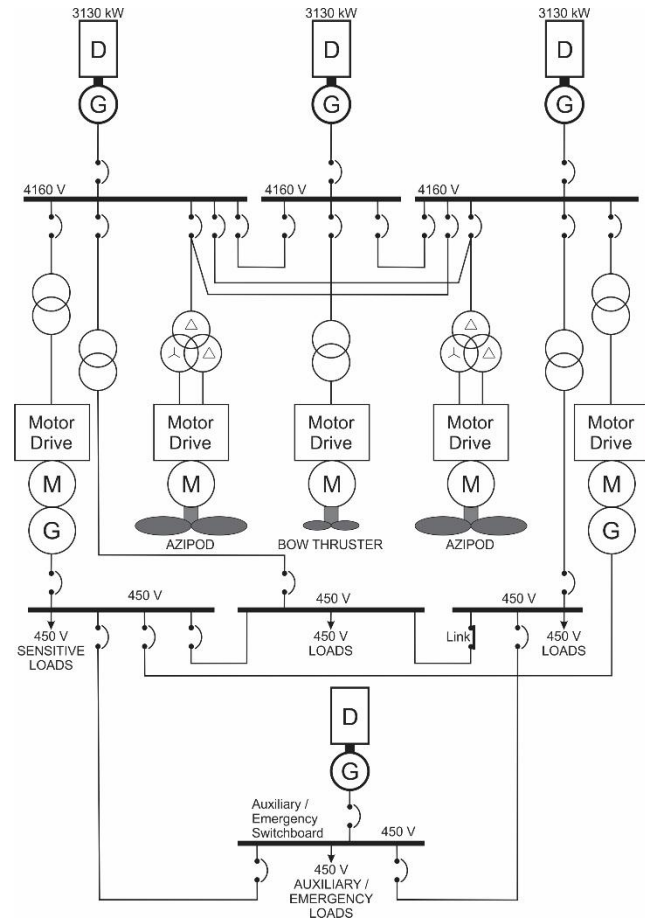

HMS Daring



HMS Daring (CC-BY-SA-3.0/Brian Burnell)

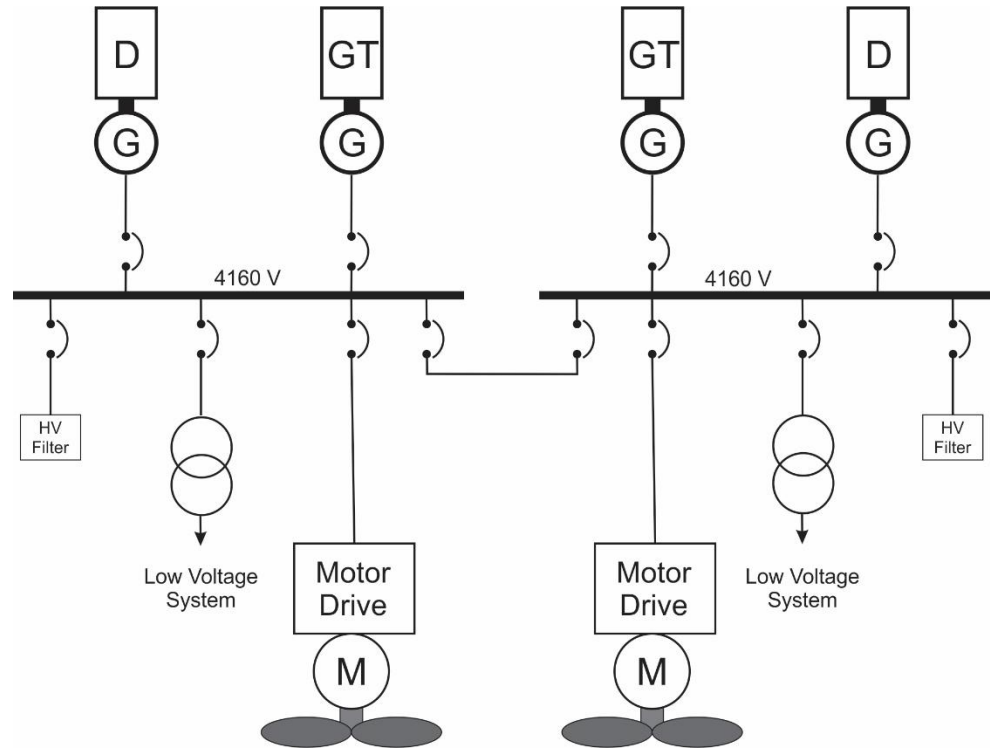

USS Makin Island

LHD 8



US Navy photo by Brett A. Anderson

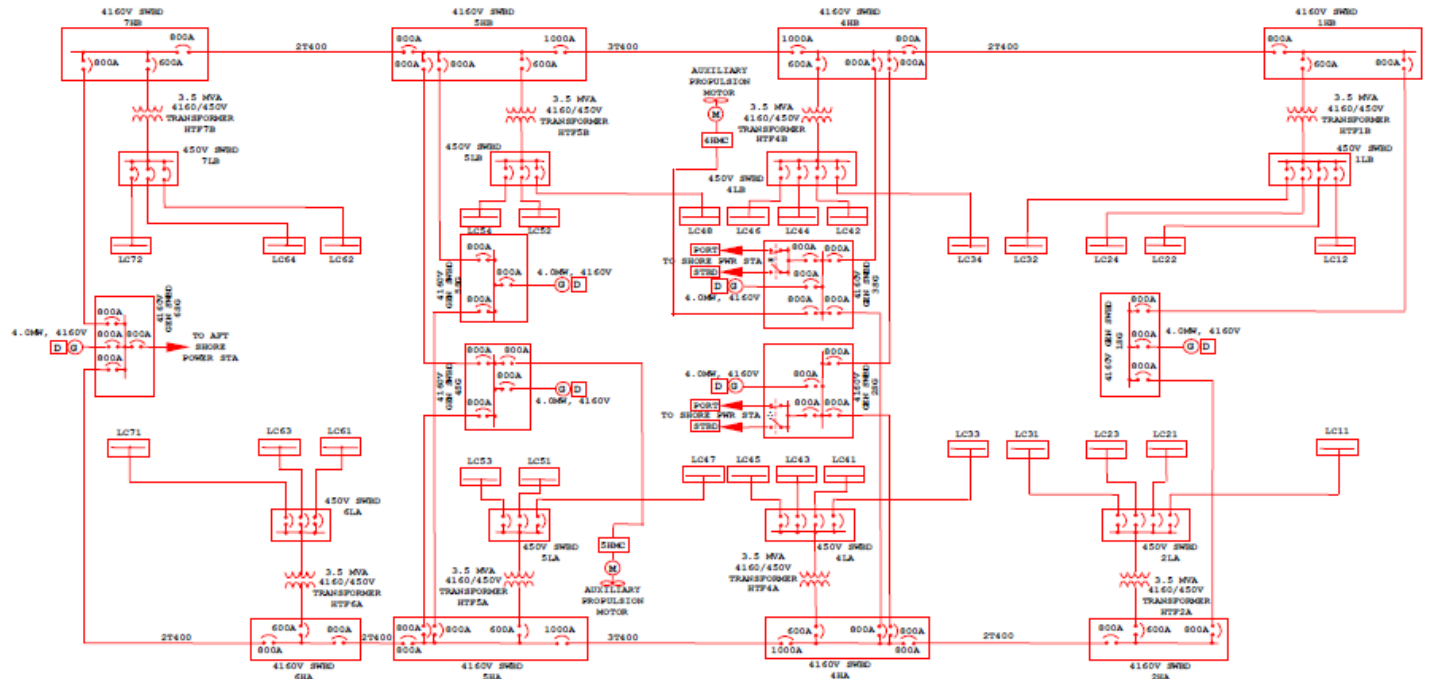

Thomas Dalton, Abe Boughner, C. David Mako, and CDR Norbert Doerry, "LHD 8: A step Toward the All Electric Warship", presented at ASNE Day 2002.

- NOTES: 1) ALL LOAD CENTERS ARE 2000A
 2) "*" , "•" , "⊙" , "⊚" = INTERLOCKED
 3) ALL 4160V CABLE TO BE TYPE LS5KV



USS Zumwalt DDG 1000

US Navy Photo by Zachery Bell

Sposato, Bill, "DDG 1000 Class Destroyer" Presented to U.S. Navy Port Engineers, 31 August 2011

